



Take Off Angles and HFTA

By Kevan Nason
N4XL

Why Use HFTA?



Have you ever asked

- ▶ How high should my antenna be?
- ▶ Is it worth spending a lot more money for a taller tower?
- ▶ My tower is 30 ft tall. Is adding 10 ft worth all the work?

Why Use HFTA?

- ▶ I'm about to buy a house. Is it in a good location for HF radio?
- ▶ Bob and I have the same antenna at the same height. We both run 100 watts. He lives 3 miles from me and often works Japan when I can't. Why?
- ▶ What antenna changes do I have to make to reach JA?

References

- A. ARRL Antenna Book, 23rd Edition
- B. Operating Instructions for HFTA, version 1.04
- C. VHF monopole antenna at variable height - 3D radiation pattern - 4NEC2 simulation – EA4FSI
- D. 5 element yagi 4nec2 antenna pattern - Felipe Ceglia

References

- E. The Radio Propagation, Luxorion,
<http://www.astrosurf.com/luxorion/qsl-propa.htm>
- F. Diffraction – wave spreading
around an edge, Blog at
Wordpress.com,
<https://esfsciencenew.wordpress.com/2009/03/26/diffraction-wave-spreading-around-an-edge/>
- G. Low Band DXing, 5th Edition,
ON4UN
- H. HFTA, ARRL, by Dean Straw, N6BV



The Decibel

The decibel is a measure of power. It makes it easy to compare things.

Power (W)	dB
100	0
200	3
400	6
800	9
1,000	10
1,500	11.7
10,000	20



Antenna Patterns & Take Off Angle

Yagi Transmit Lobes

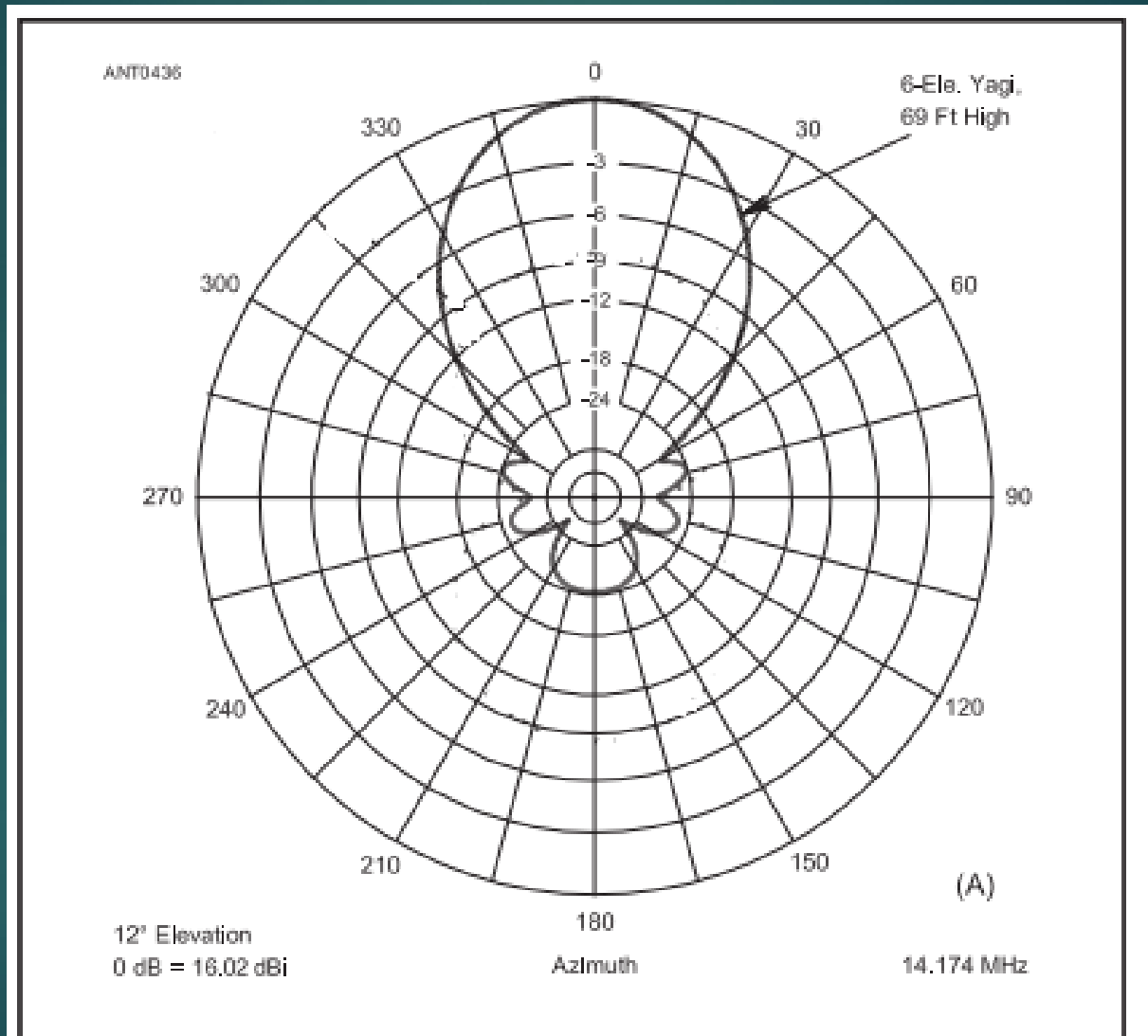

3D Yagi Transmit Lobes

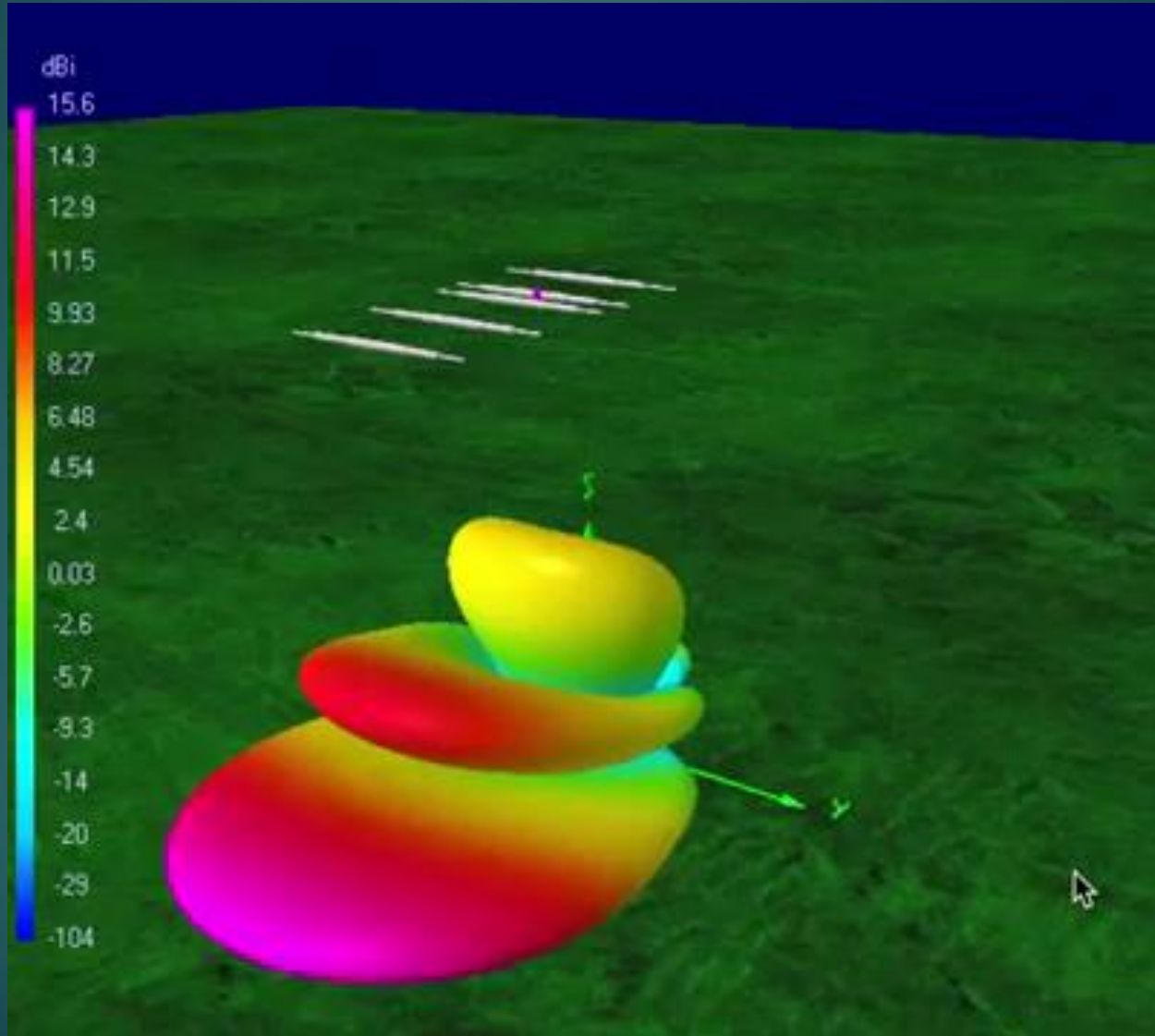

Take Off and Arrival Angles

ANT0820

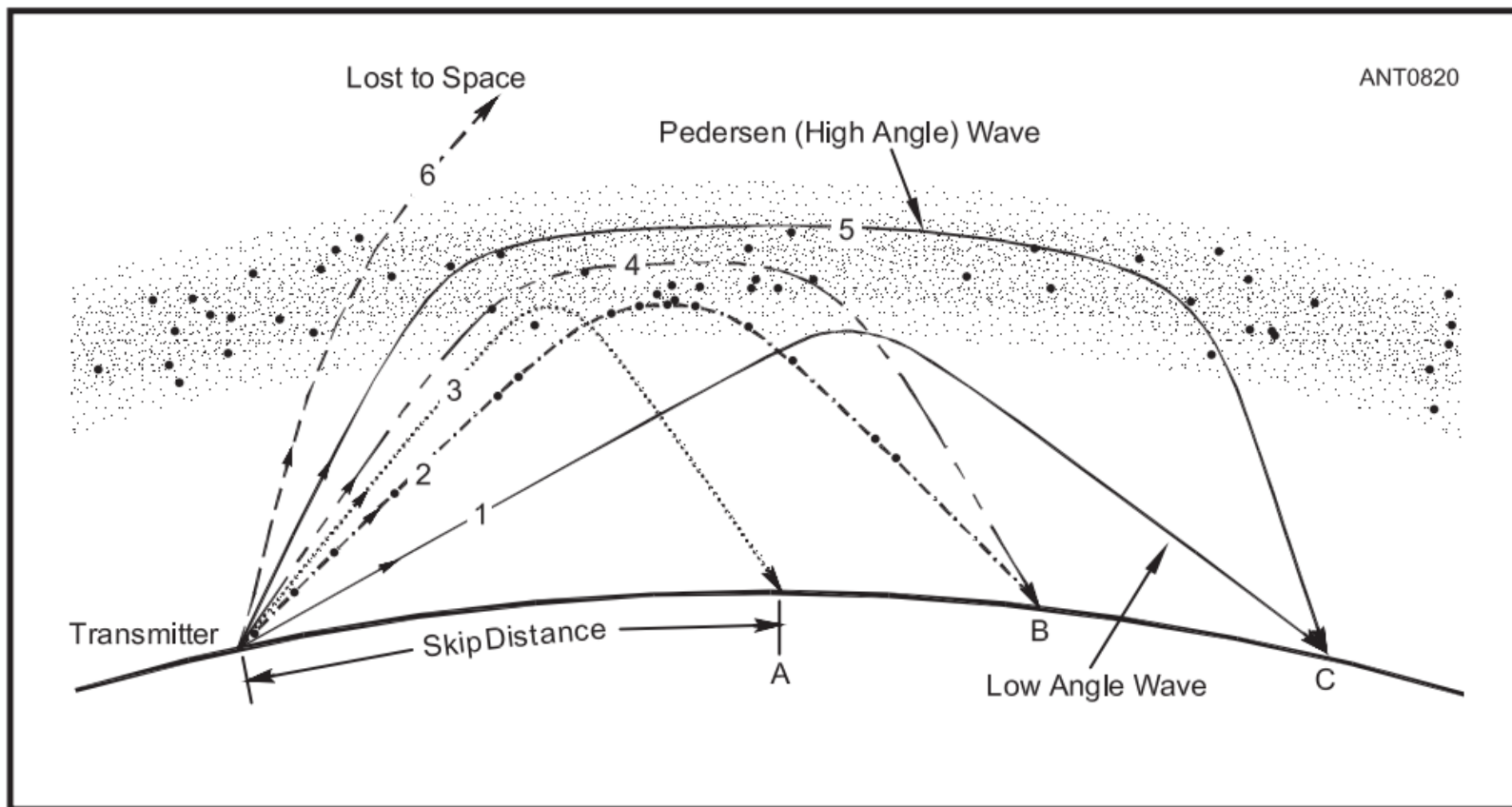

Figure 4.22 — Very simplified smooth-Earth/ionosphere dia-

Take Off and ARRIVAL Angles

Table 5-1

Range of Radiation Angles for 40 and 80 Meters for Various Paths

The values are averages across the complete sunspot cycle and across the seasons. The value between parentheses is the most common radiation angle (peak value in the distribution).

<i>From</i>	<i>Path to</i>	<i>40 Meters</i>	<i>80 Meters</i>
W. Europe (Belgium)	Southern Africa	1-18 (5)	1-17 (5)
	Japan	1-19 (3)	2-17 (3)
	Oceania	1-4 (1)	No Data
	South Asia	1-17 (4)	3-5 (4)
	USA (W1-W6)	2-33 (5)	1-35 (4)
	South America	1-17 (1)	1-12 (1)
USA East Coast	Southern Africa	1-16 (3)	3-4 (4)
	Japan	1-15 (1)	1-12 (5)
	Oceania	1-9 (1)	No Data
	South Asia	1-9 (1)	No Data
	South America	1-23 (5)	1-21 (10)
	Europe	1-38 (6)	1-31 (13)

Take Off Angle and Height

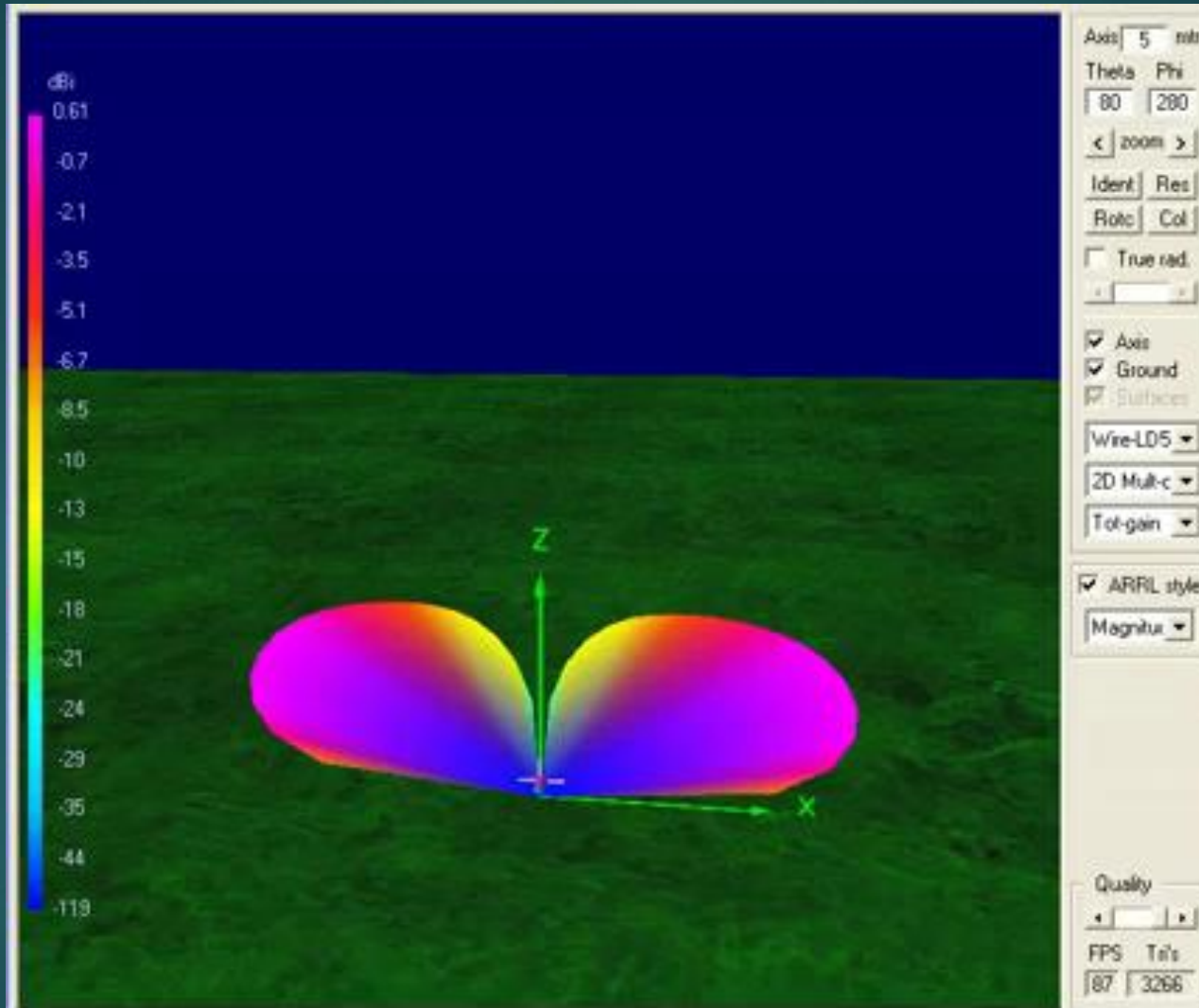



HFTA

(HF Terrain Assessment)

The Plot Area

Take Off Angle and Height

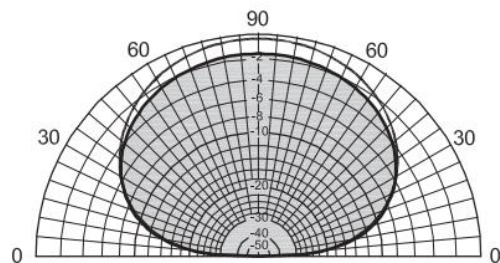

A - Antenna $1/8 \lambda$ high

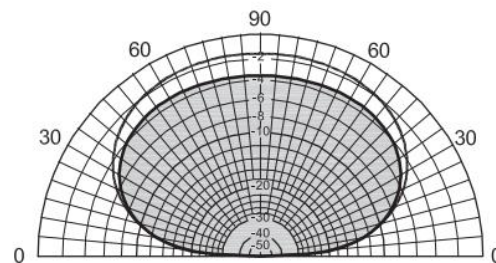

B - Antenna $1/4 \lambda$ high

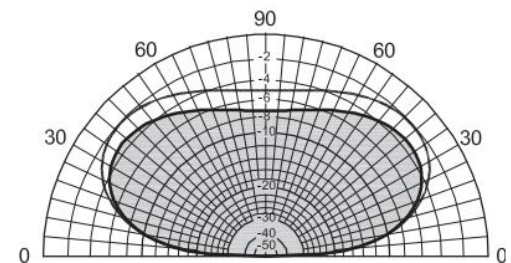

C - Antenna $3/8 \lambda$ high

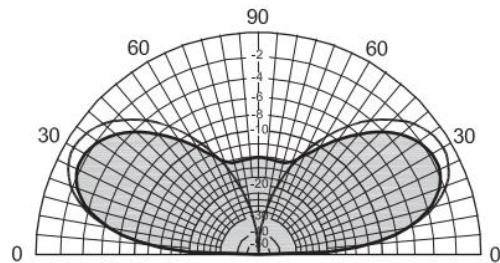

D - Antenna $1/2 \lambda$ high

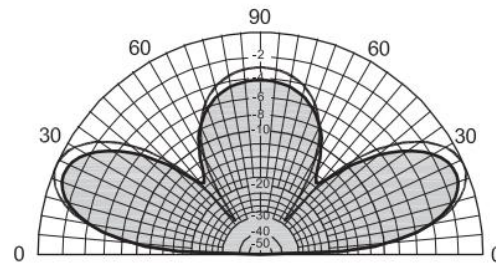

E - Antenna $5/8 \lambda$ high

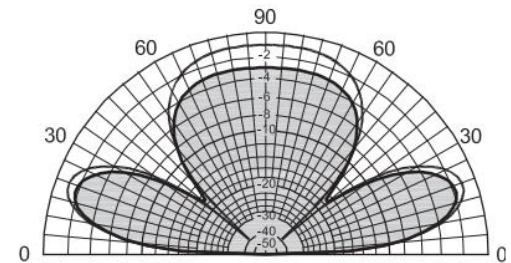

F - Antenna $3/4 \lambda$ high

Take Off Angle Graph

Rotate

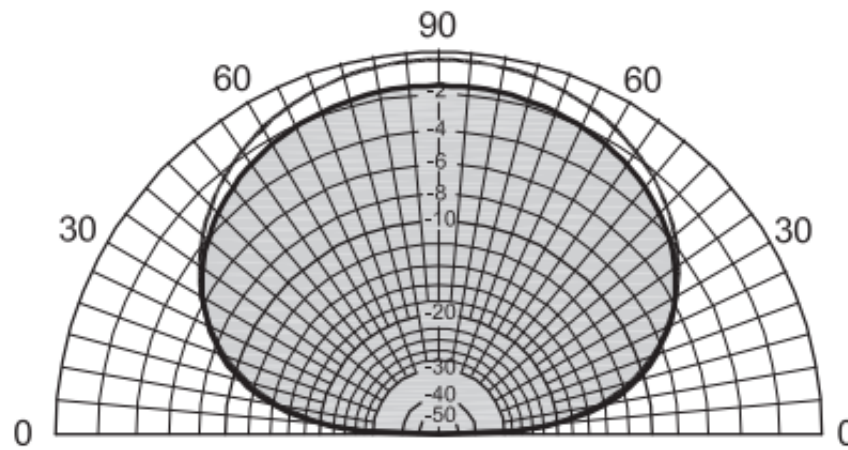

A - Antenna $1/8 \lambda$ high

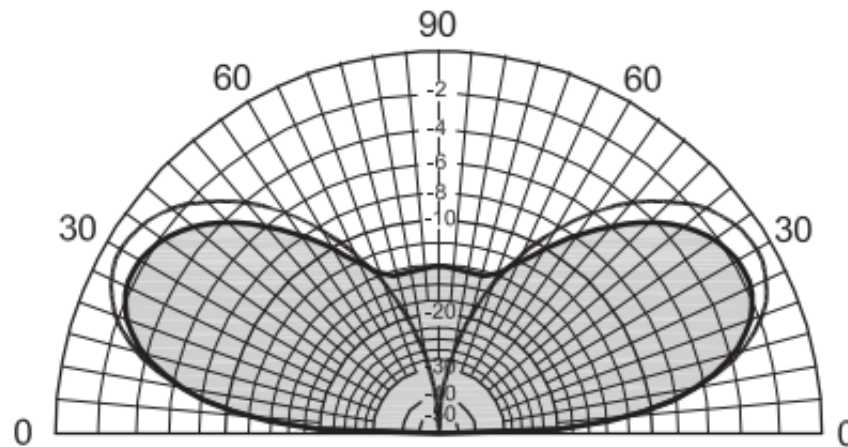

D - Antenna $1/2 \lambda$ high

HFTA Take Off Angle Graph

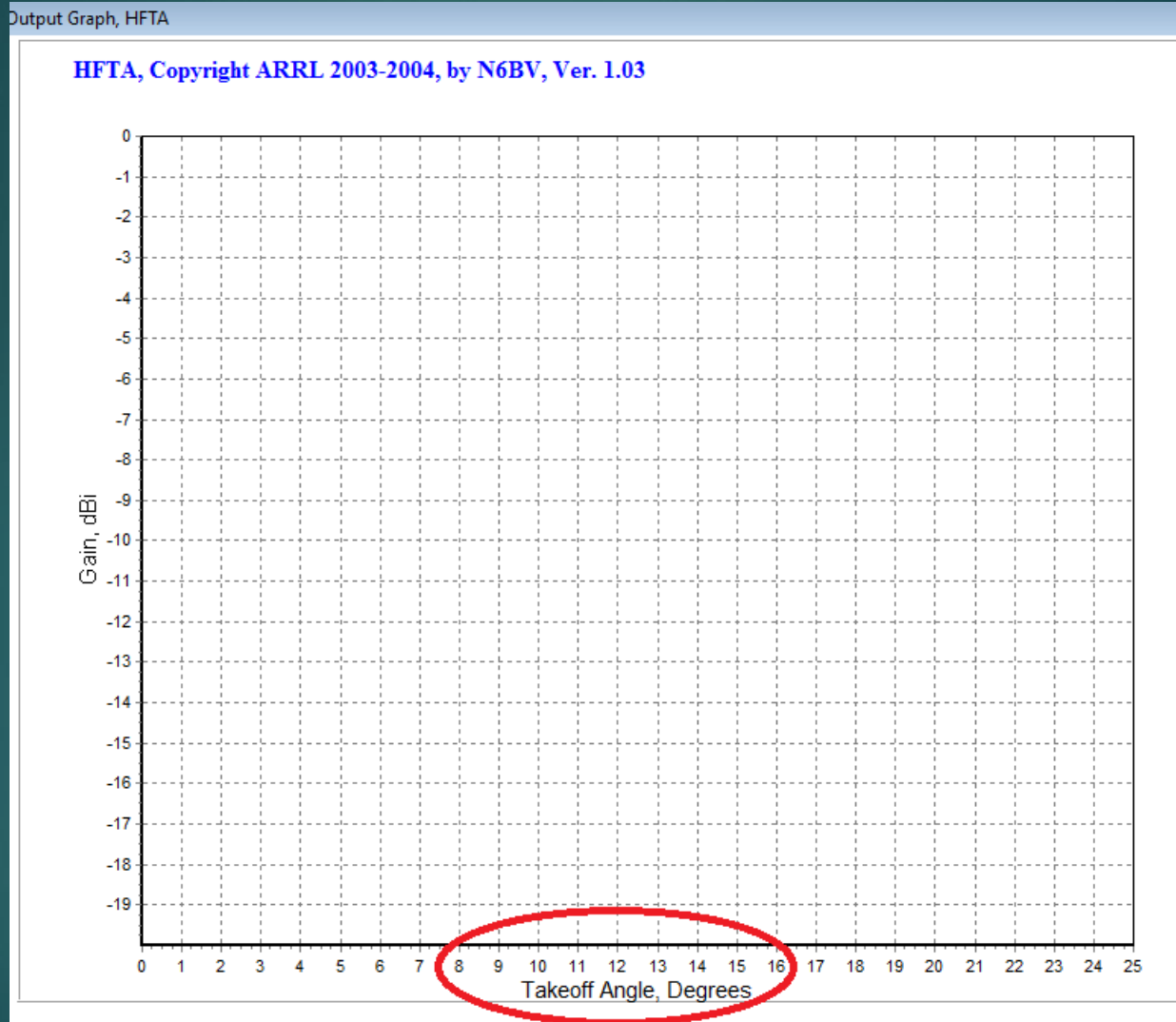

HFTA - Lobe

Lobes

Output Graph, HFTA

x

HFTA, Copyright ARRL 2003-2004, by N6BV, Ver. 1.03

Freq. = 28.4 MHz
Max. Gain: 12.9 dBi

FLAT.PRO

50 ft

3-Ele.

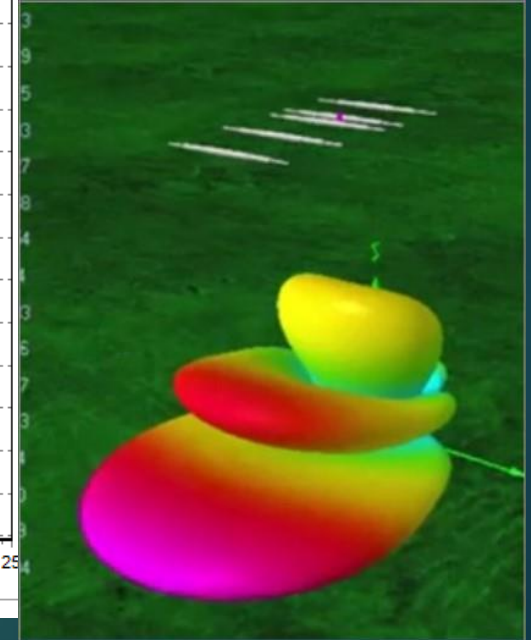
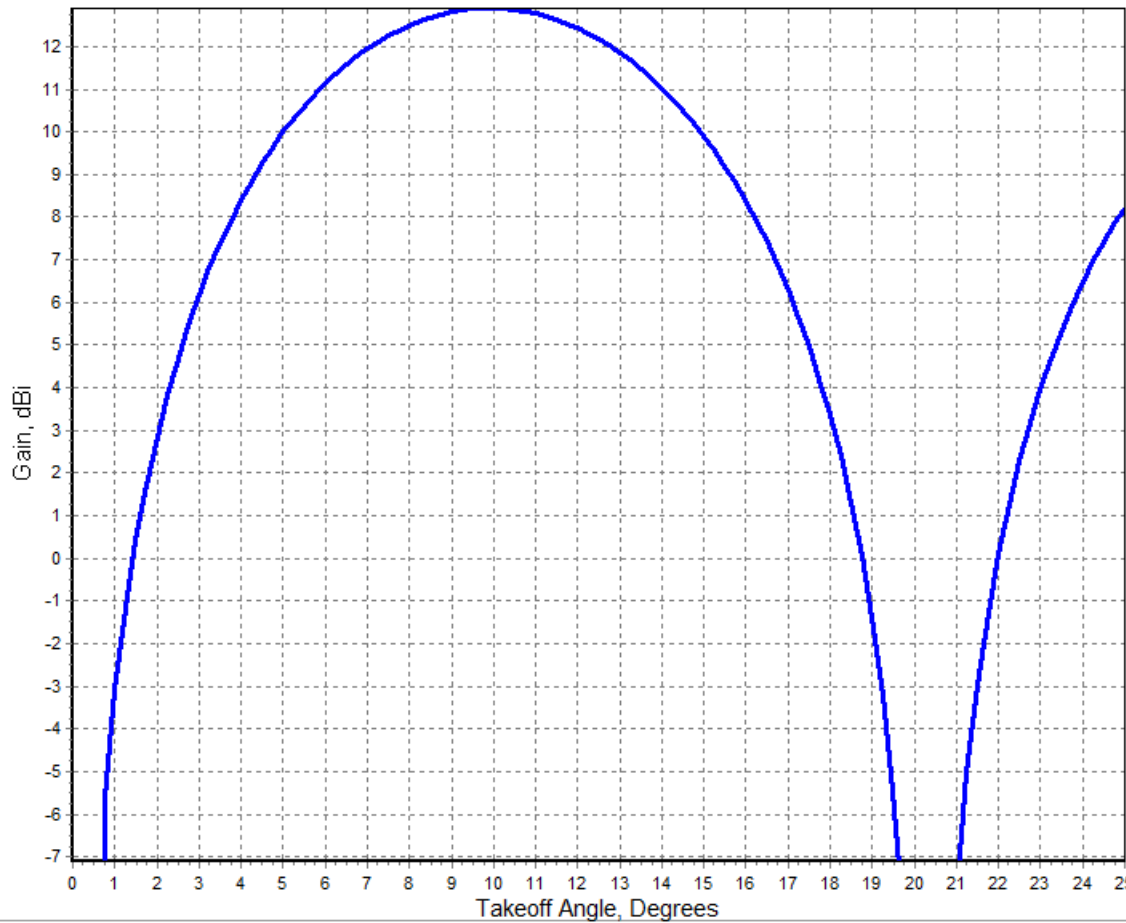

HFTA Elevation Statistics

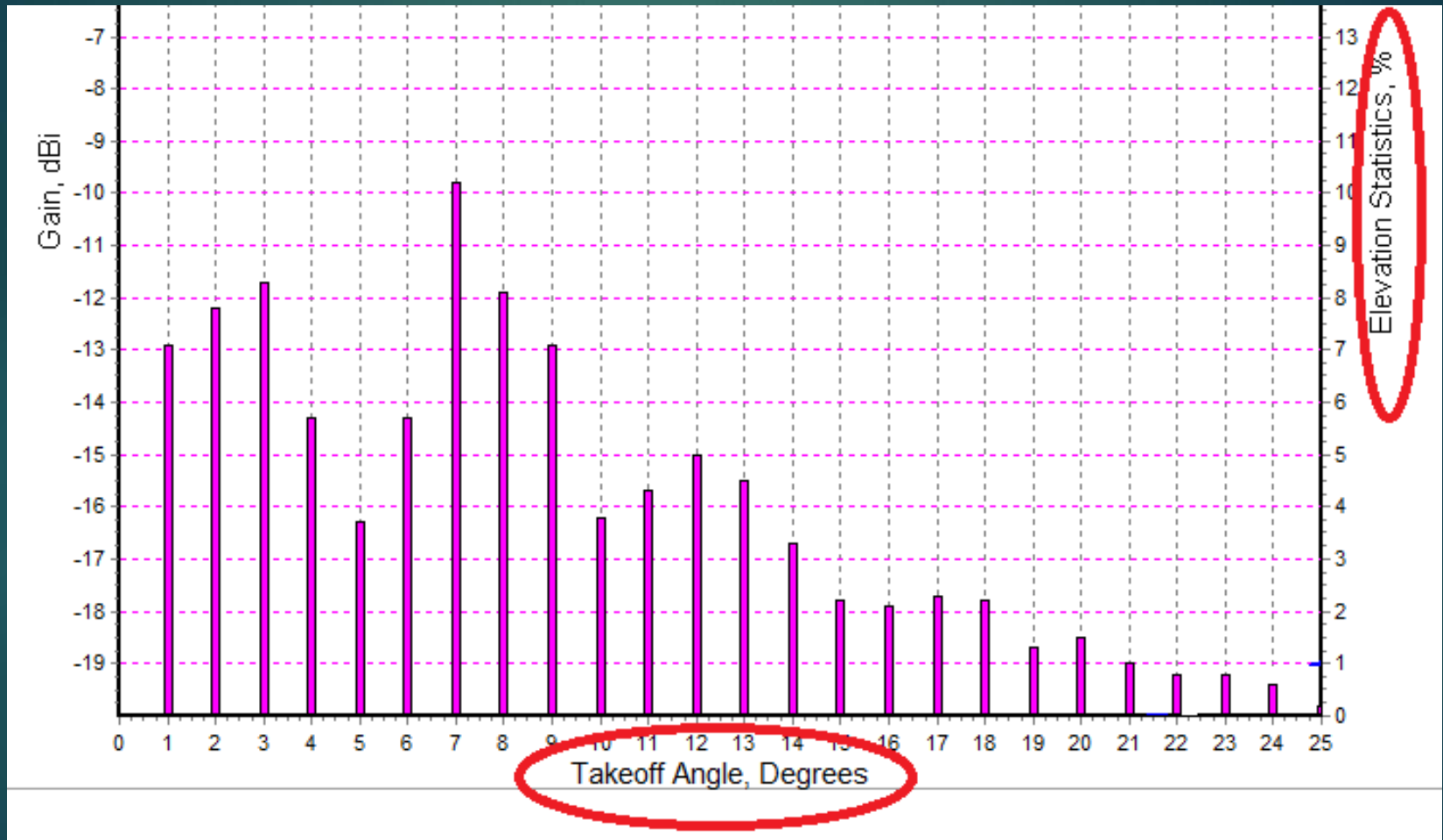

HFTA – Lobe & Statistics - EU

Output Graph, HFTA

HFTA, Copyright ARRL 2003-2004, by N6BV, Ver. 1.03

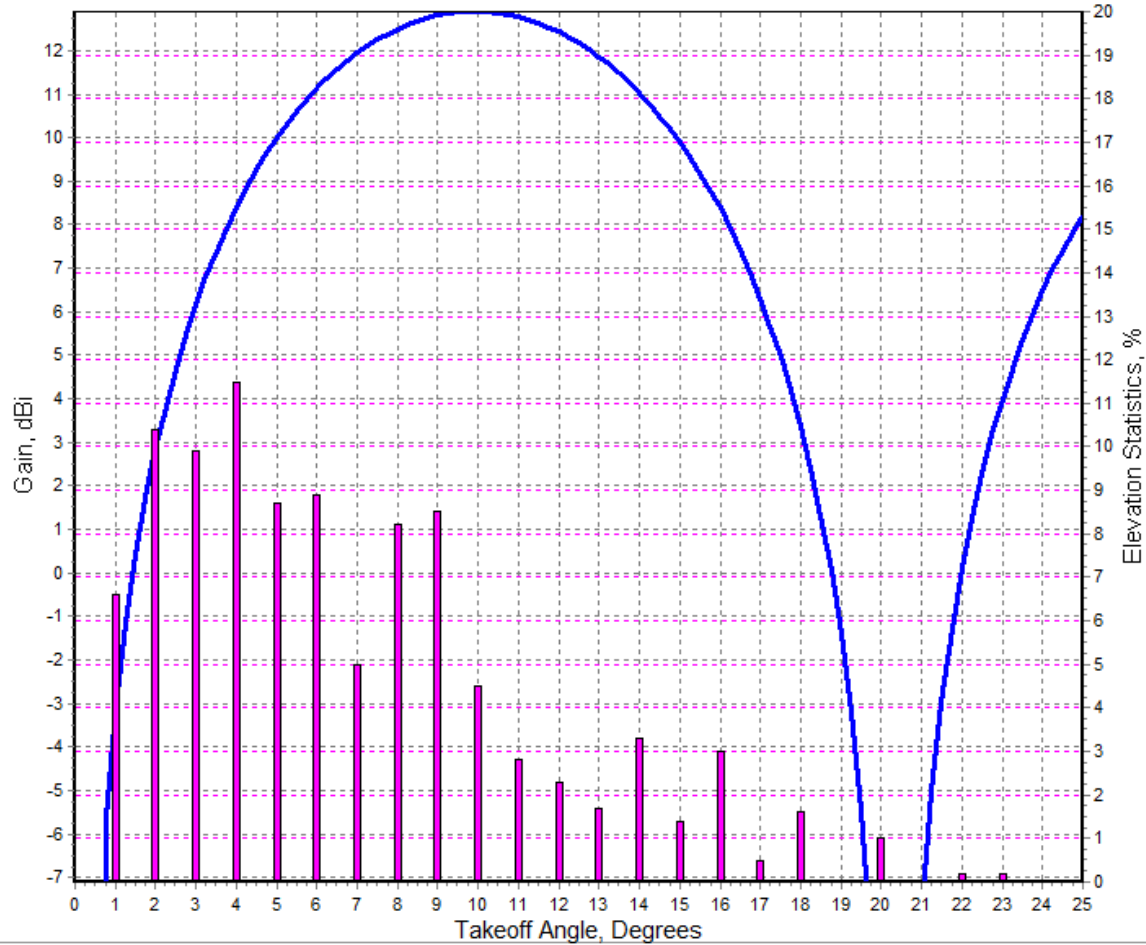

Freq. = 28.4 MHz
Max. Gain: 12.9 dBi
FLAT.PRO
50 ft
3-Ele.
Fig. of Merit: 10.1

Elev. Statistic
W4-SC-EU.PRN

Print Out File

Close Open OU

HFTA – Lobe & Statistics - AS

Output Graph, HFTA

HFTA, Copyright ARRL 2003-2004, by N6BV, Ver. 1.03

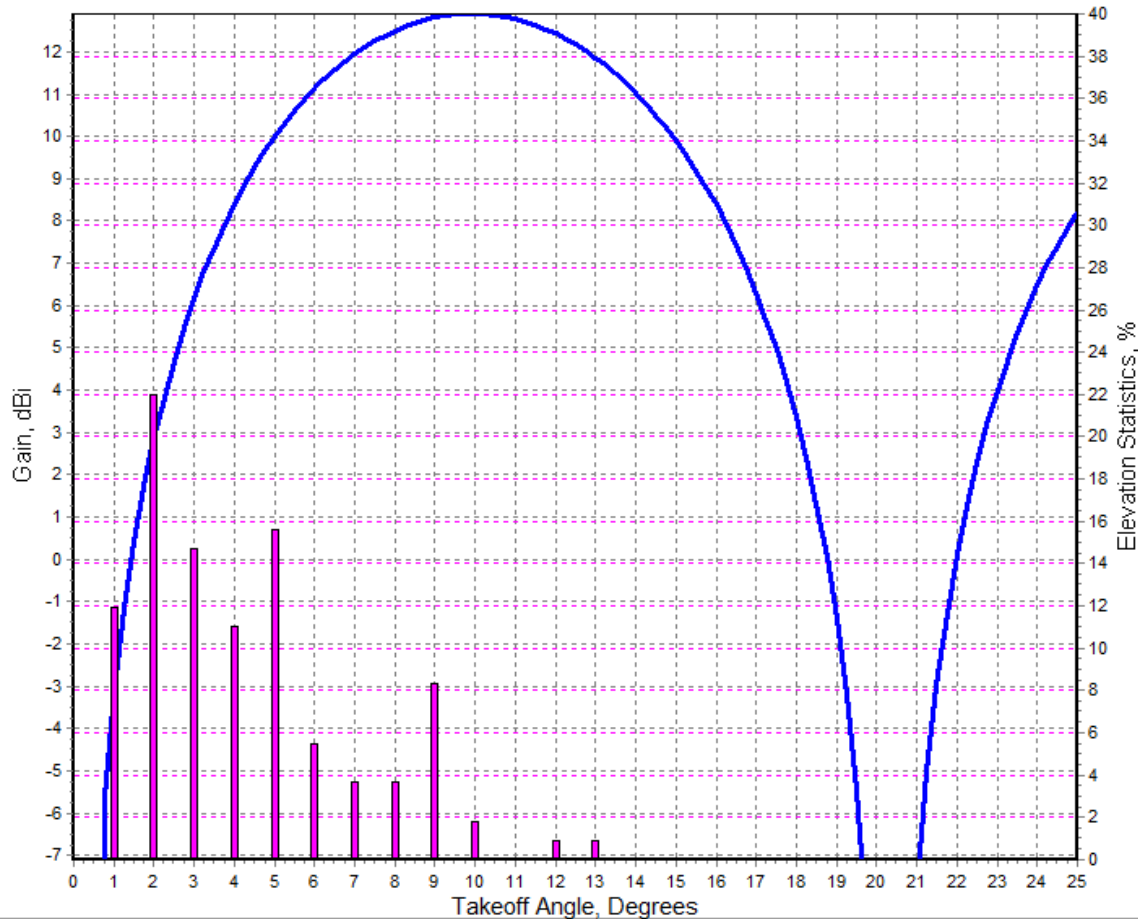

Freq. = 28.4 MHz
Max. Gain: 12.9 dBi
FLAT.PRO
50 ft
3-Ele.
Fig. of Merit: 8.8

Elev. Statistic
W4-SC-AS.PRN

Print

Out File

Close

HFTA – 30 vs 70 ft

Output Graph, HFTA

HFTA, Copyright ARRL 2003-2004, by N6BV, Ver. 1.03

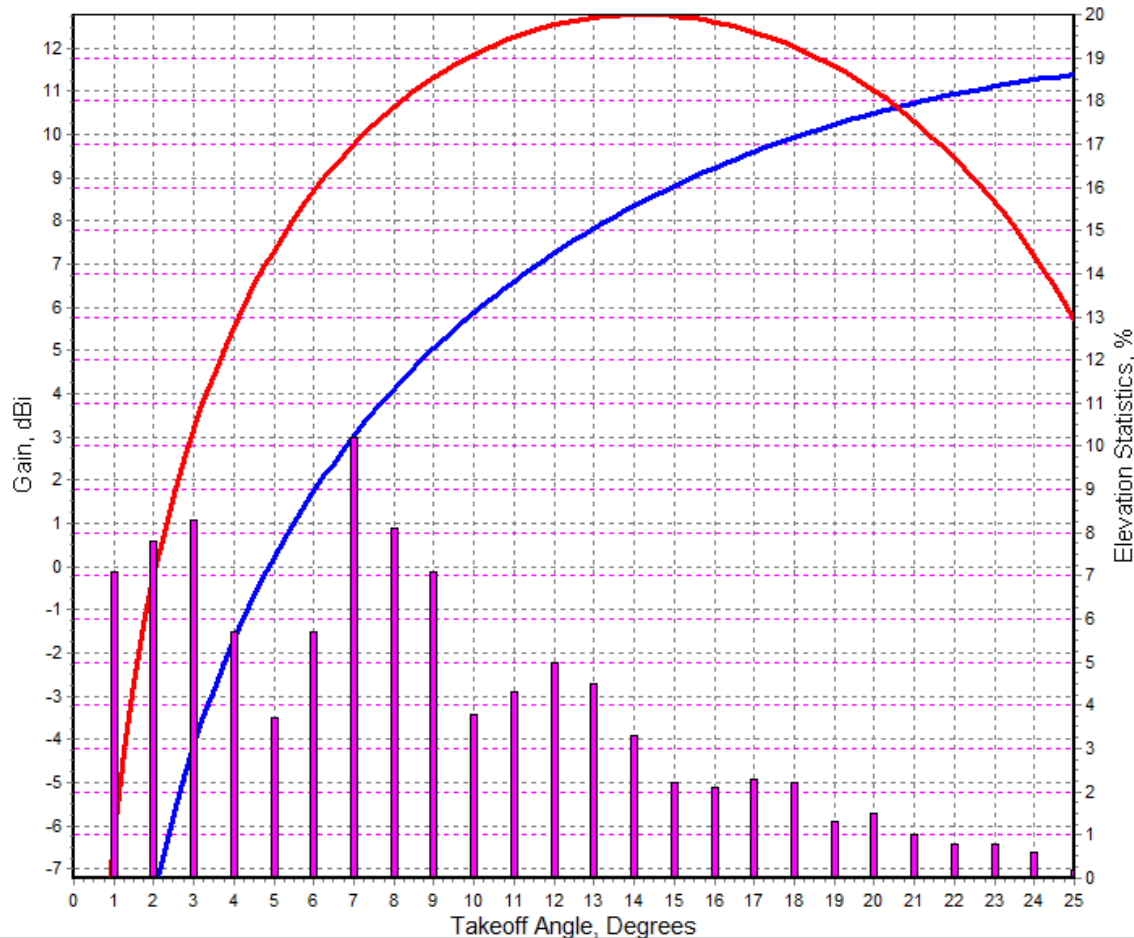

Freq. = 14.2 MHz
Max. Gain: 12.8 dBi

FLAT.PRO
30 ft
3-Ele.
Fig. of Merit: 5.4

FLAT.PRO
70 ft
3-Ele.
Fig. of Merit: 9.9

Elev. Statistic
W4-SC-EU.PRN

Print

Out File

Close

HFTA - 50-70-180

HFTA, Copyright ARRL 2003-2004, by N6BV, Ver. 1.03

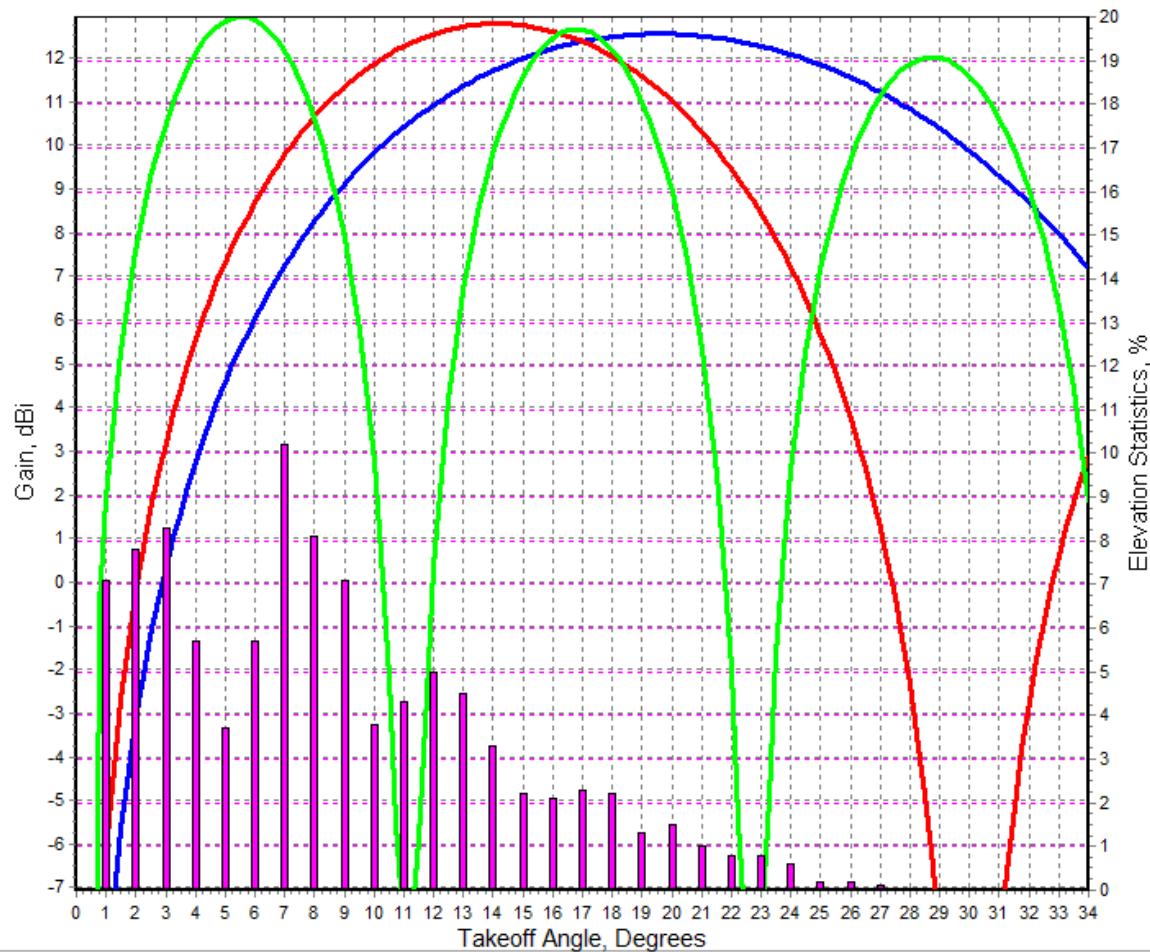

Freq. = 14.2 MHz
Max. Gain: 12.9 dBi

FLAT.PRO
50 ft
3-Ele.
Fig. of Merit: 8.7

FLAT.PRO
70 ft
3-Ele.
Fig. of Merit: 9.9

FLAT.PRO
180 ft
3-Ele.
Fig. of Merit: 9.9

Elev. Statistic
W4-SC-EU.PRN

Print

Out File

Close

HFTA – 50-70-180 at 11 degrees

HFTA, Copyright ARRL 2003-2004, by N6BV, Ver. 1.03

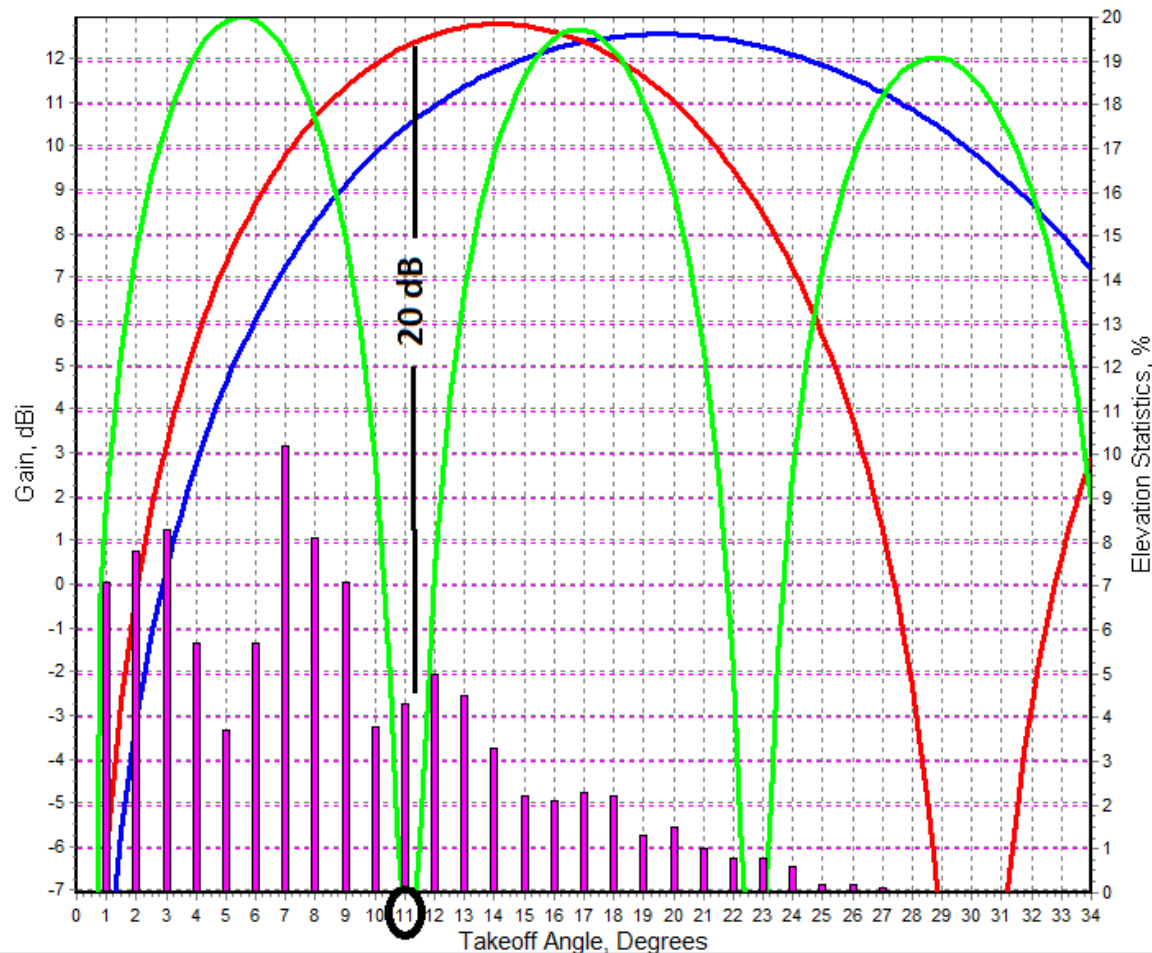

Freq. = 14.2 MHz
Max. Gain: 12.9 dBi

FLAT.PRO
50 ft
3-Ele.
Fig. of Merit: 8.7

FLAT.PRO
70 ft
3-Ele.
Fig. of Merit: 9.9

FLAT.PRO
180 ft
3-Ele.
Fig. of Merit: 9.9

Elev. Statistic
W4-SC-EU.PRN

Print

Out File

Close

20 dB is the same
as increasing power
from 100 watts to
10,000 watts



HFTA

(HF Terrain Assessment)

Stacks

HFTA – 70/140 ft Stack

HFTA, Copyright ARRL 2003-2004, by N6BV, Ver. 1.03

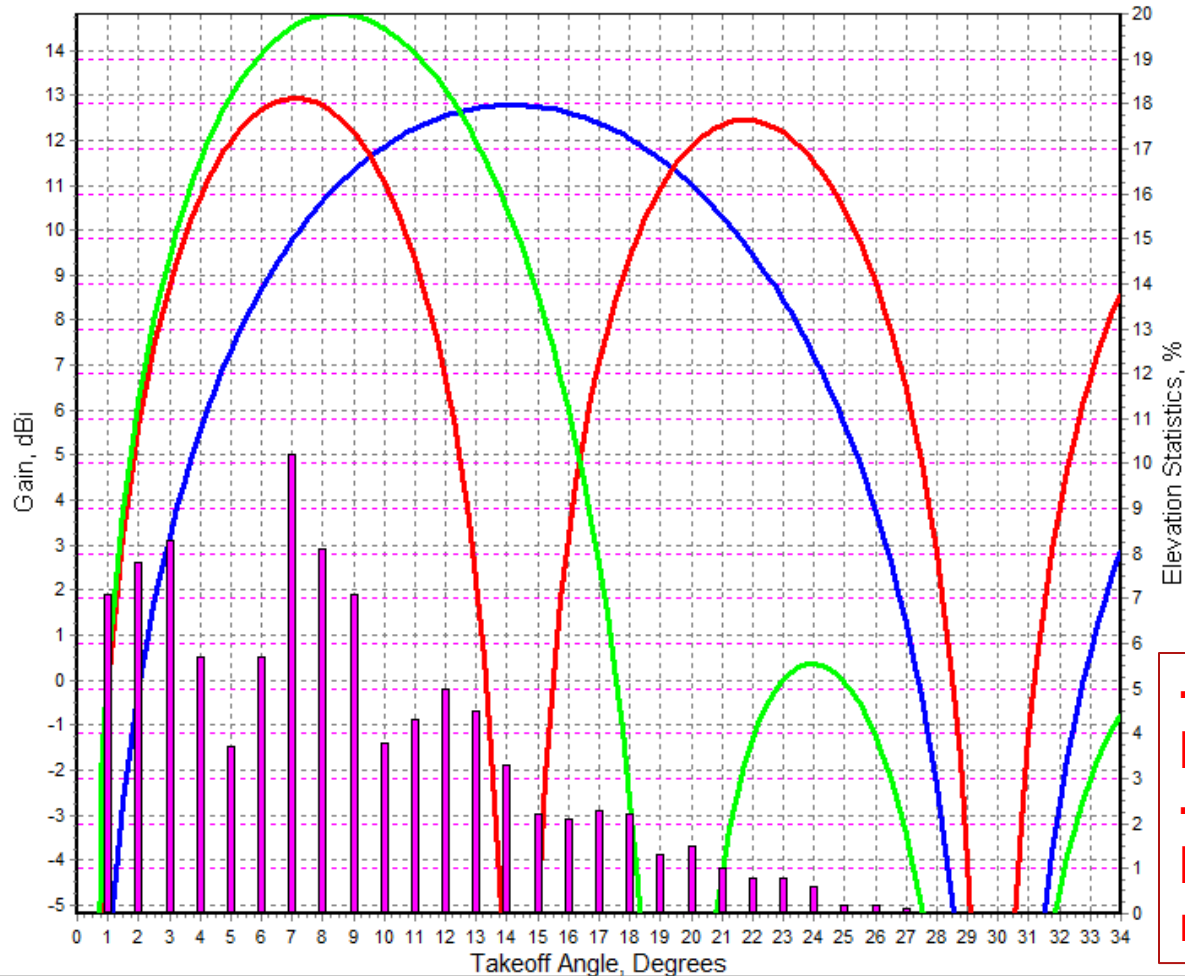

Freq. = 14.2 MHz
Max. Gain: 14.8 dBi
FLAT.PRO
70 ft
3-Ele.
Fig. of Merit: 9.9
FLAT.PRO
140 ft
3-Ele.
Fig. of Merit: 10.2
FLAT.PRO
70/140 ft
3-Ele.
Fig. of Merit: 12.1

Elev. Statistic
W4-SC-EU.PRN

Print Out File
Close

- Can use one or both antennas
- Combo shows higher angle rejection

HFTA – 35/70 ft Stack to US

HFTA, Copyright ARRL 2003-2004, by N6BV, Ver. 1.03

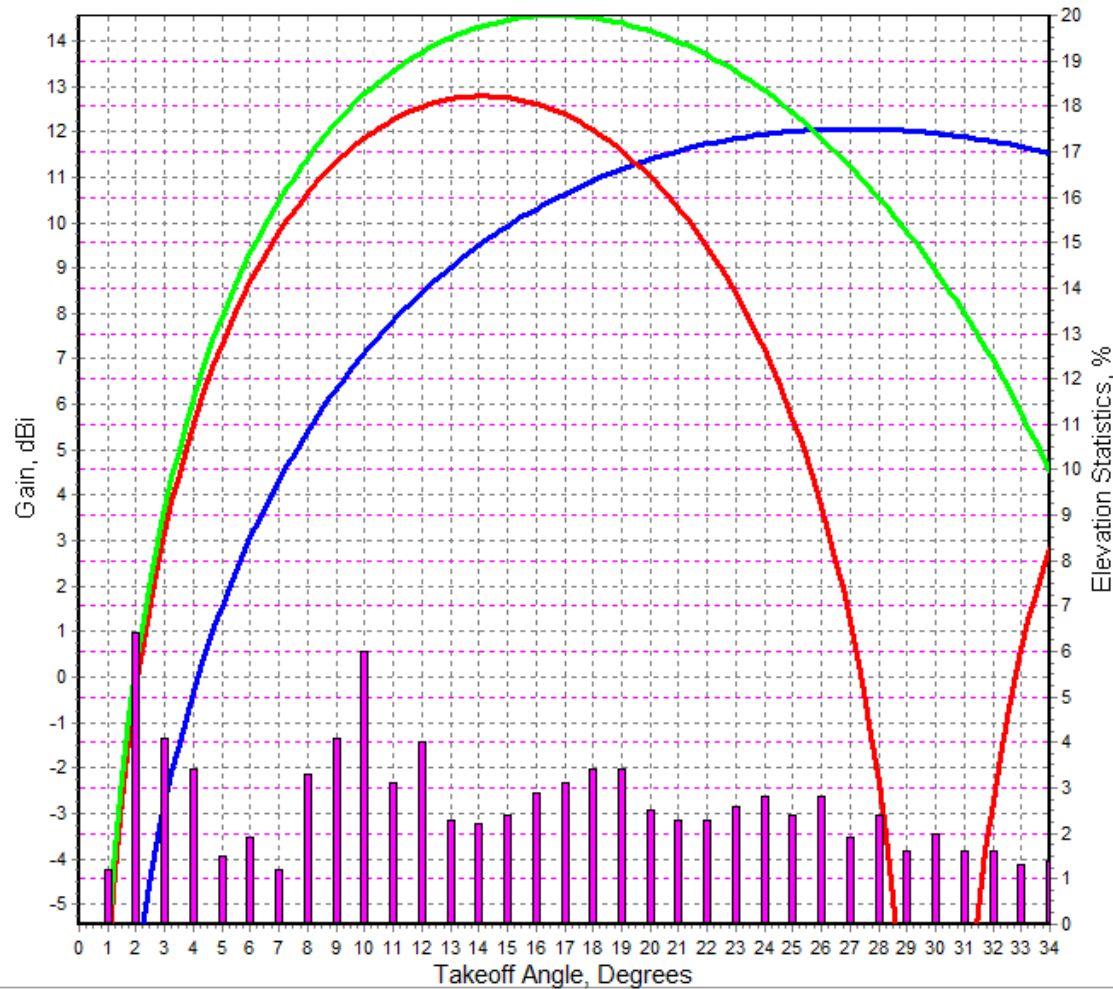

Freq. = 14.2 MHz

Max. Gain: 14.6 dBi

FLAT.PRO

35 ft

3-Ele.

Fig. of Merit: 9.2

FLAT.PRO

70 ft

3-Ele.

Fig. of Merit: 9.3

FLAT.PRO

35/70 ft

3-Ele.

Fig. of Merit: 11.7

Elev. Statistic

W4-SC-US.PRN

Print

Out File

Close

HFTA – 35/70 ft Out of Phase

HFTA, Copyright ARRL 2003-2004, by N6BV, Ver. 1.03

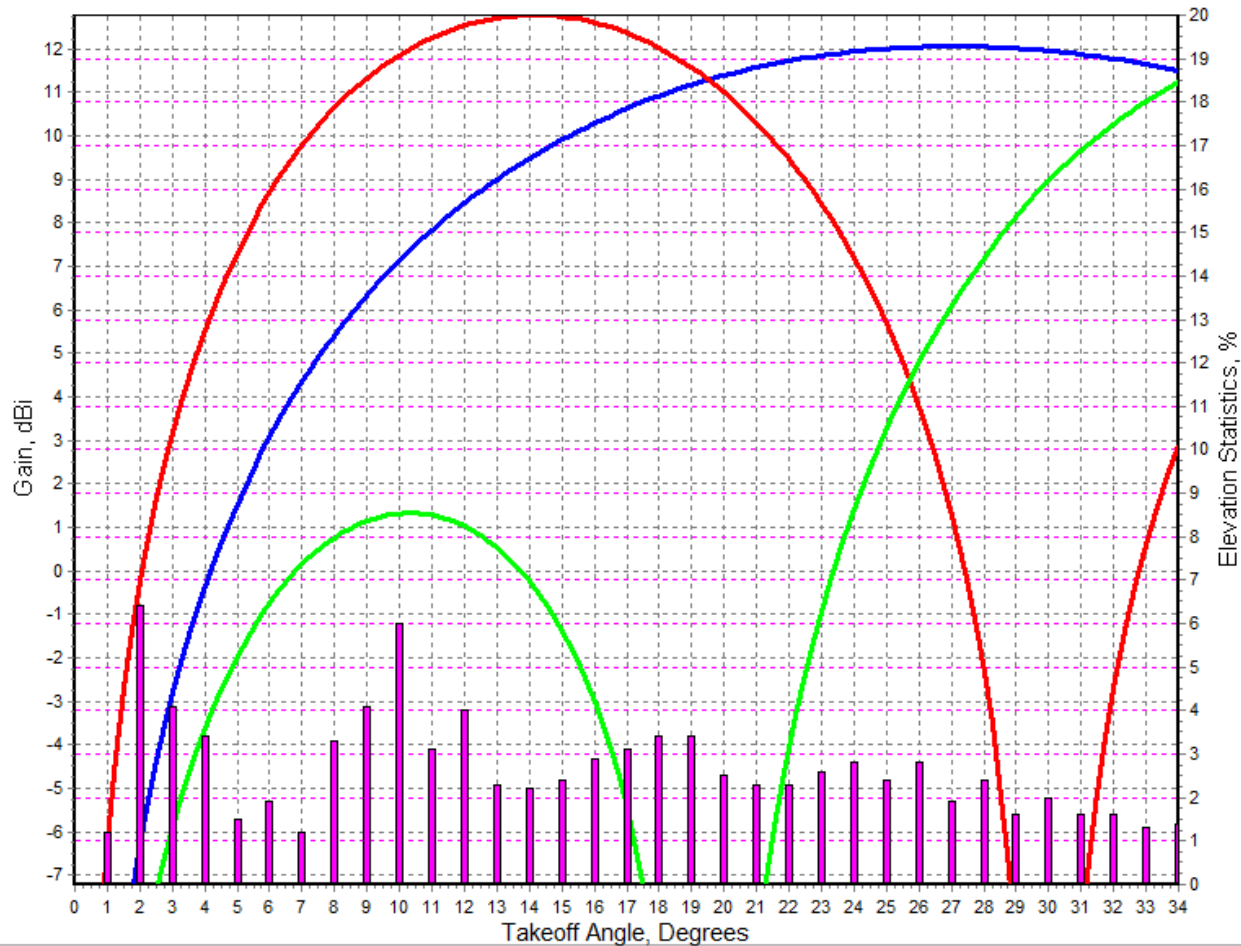

Freq. = 14.2 MHz

Max. Gain: 12.8 dBi

FLAT.PRO

35 ft

3-Ele.

Fig. of Merit: 9.2

FLAT.PRO

70 ft

3-Ele.

Fig. of Merit: 9.3

FLAT.PRO

35/70* ft

3-Ele.

Fig. of Merit: 2.7

Elev. Statistic

W4-SC-US.PRN

Print

Out File

Close

Here the 70 ft antenna is out of phase



HFTA

(HF Terrain Assessment)

Terrain Effects

Terrain effects

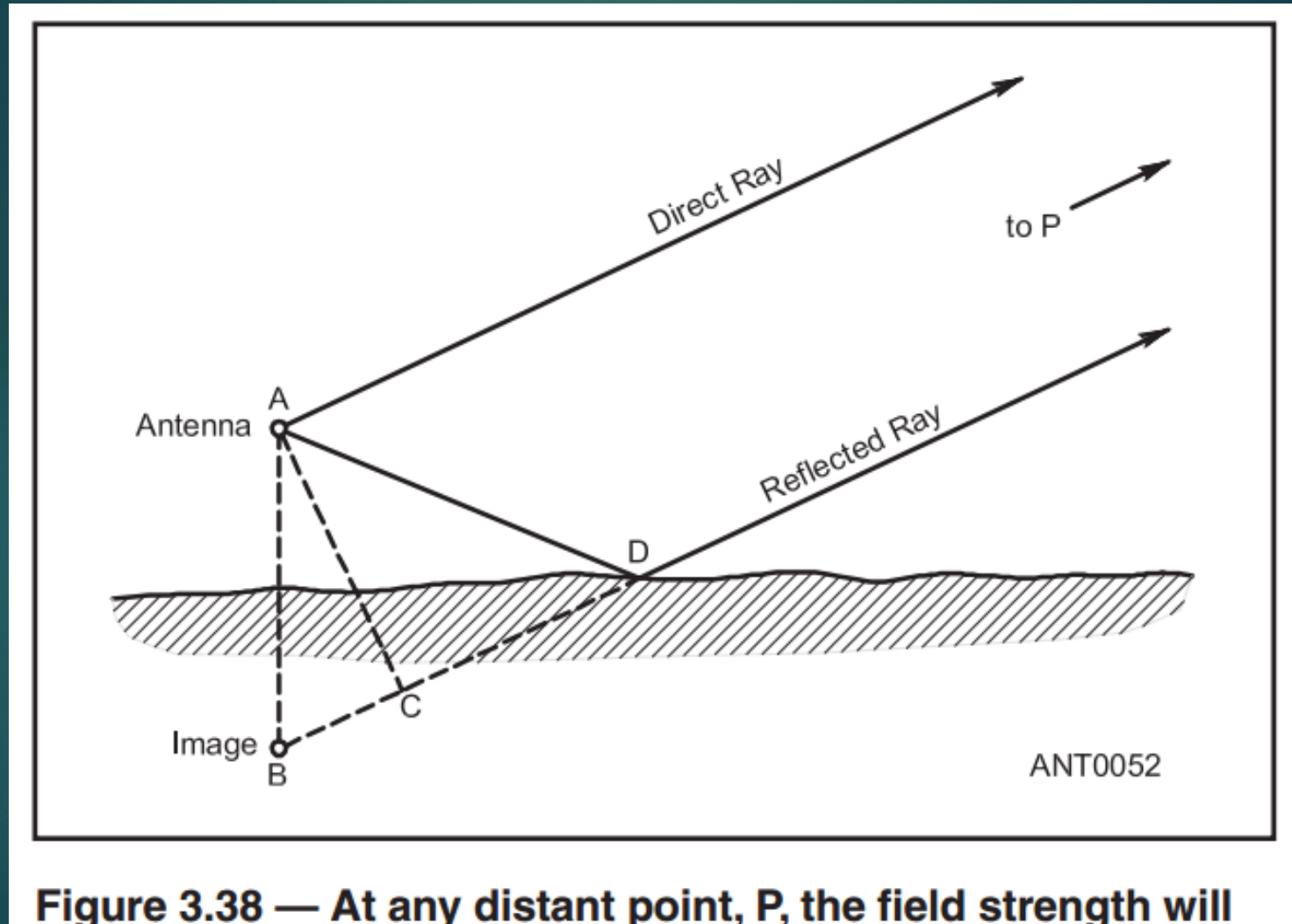
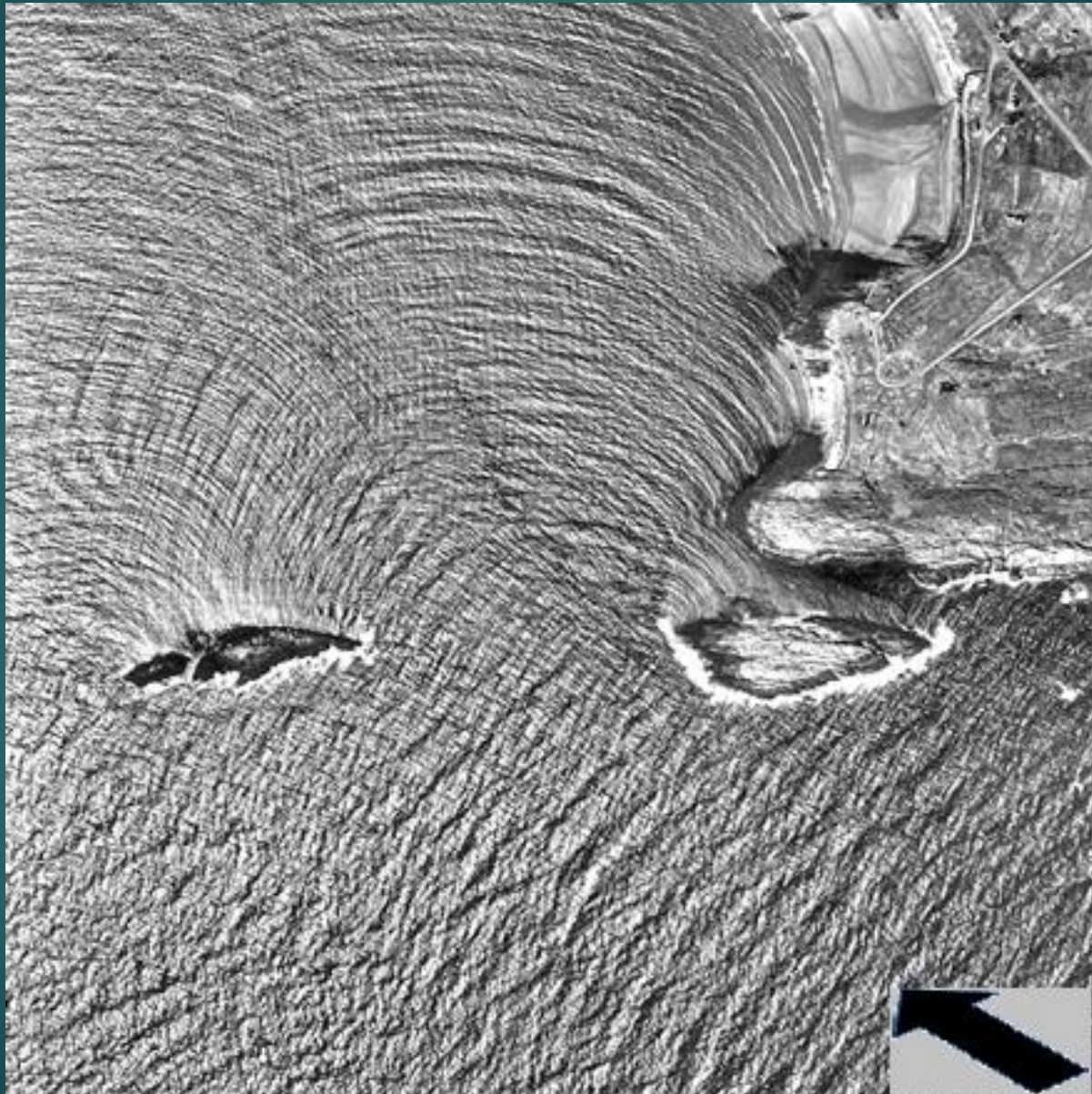
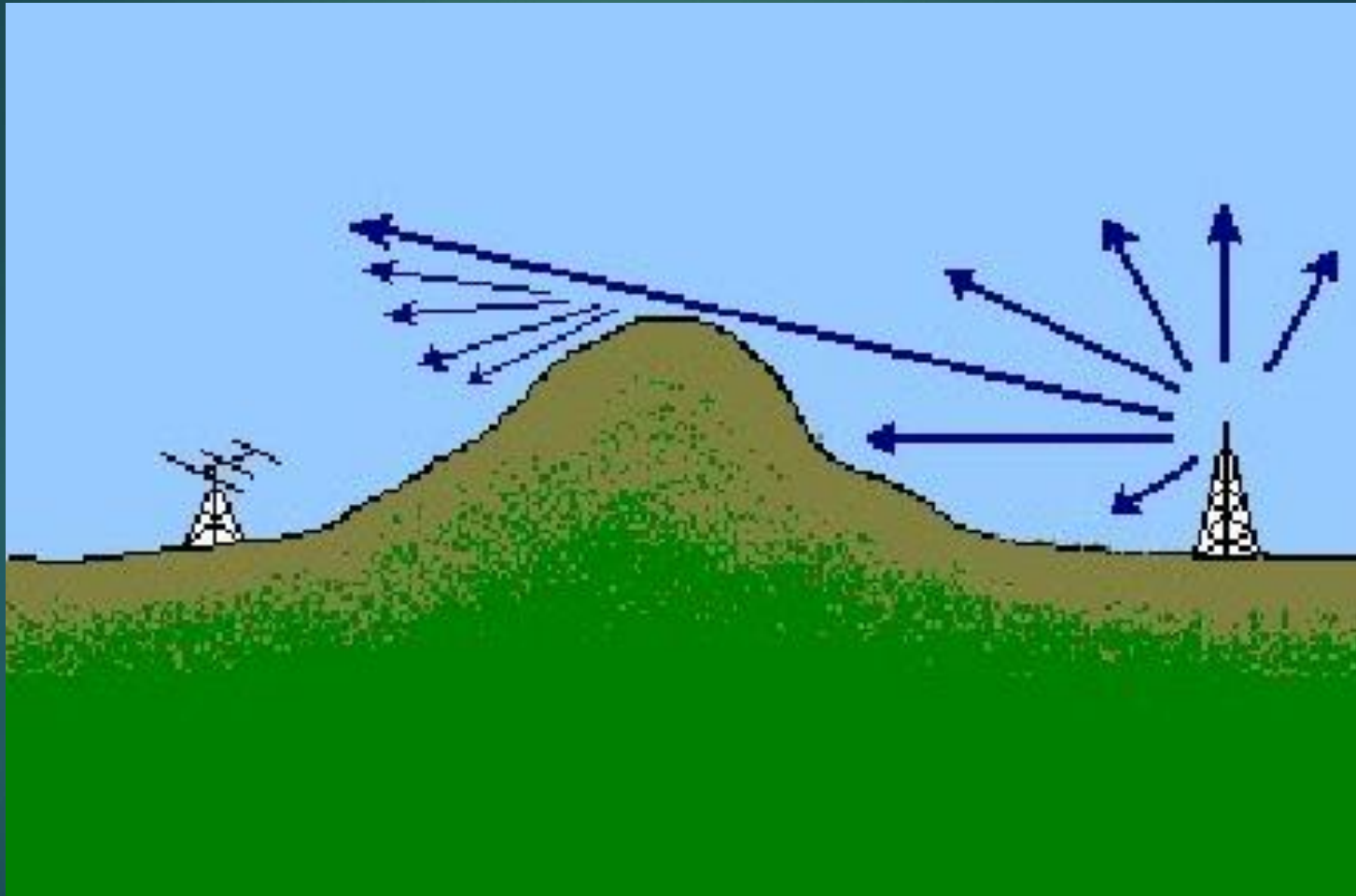

Figure 3.38 — At any distant point, P, the field strength will

Terrain effects



Terrain effects



Terrain effects

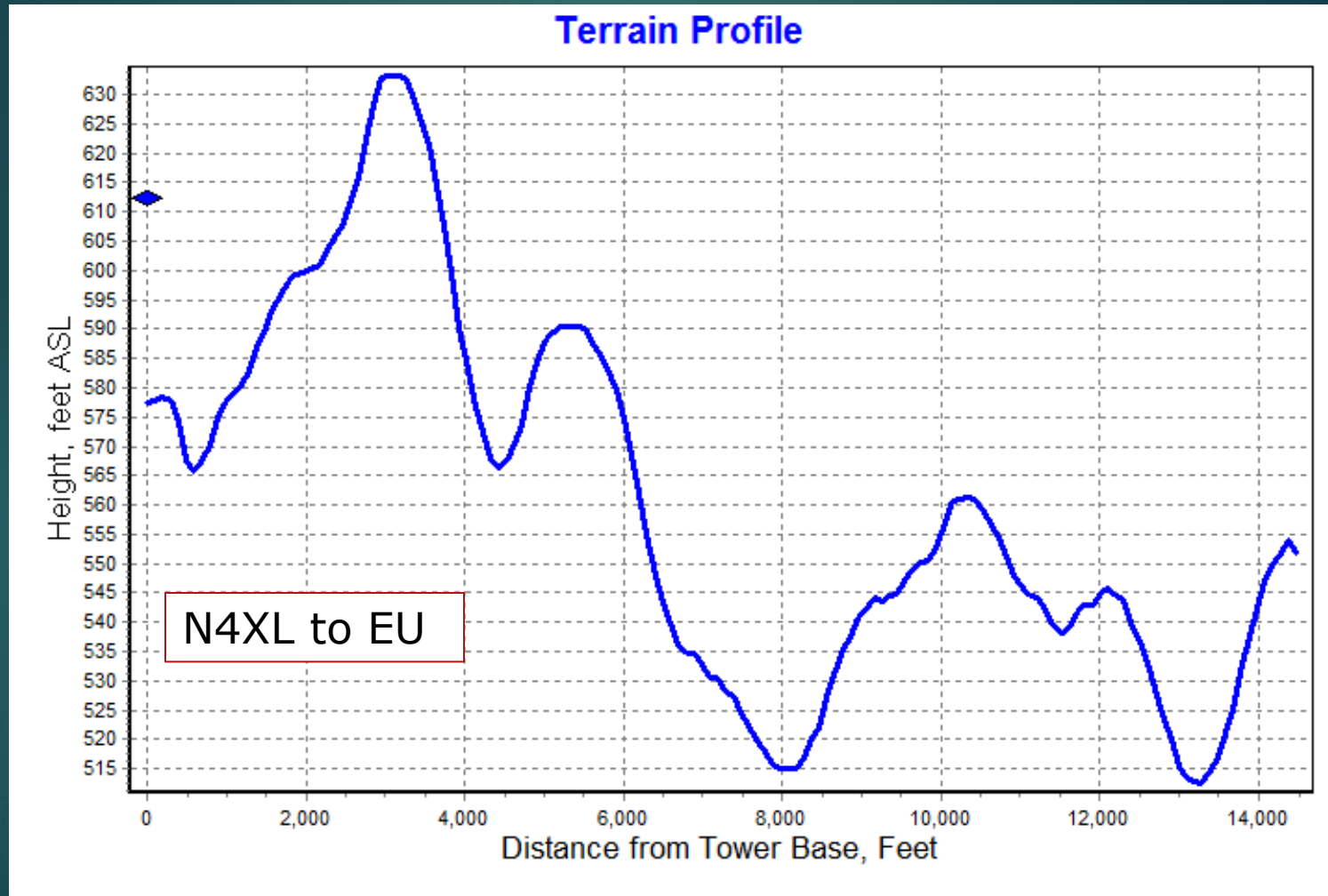

Terrain effects

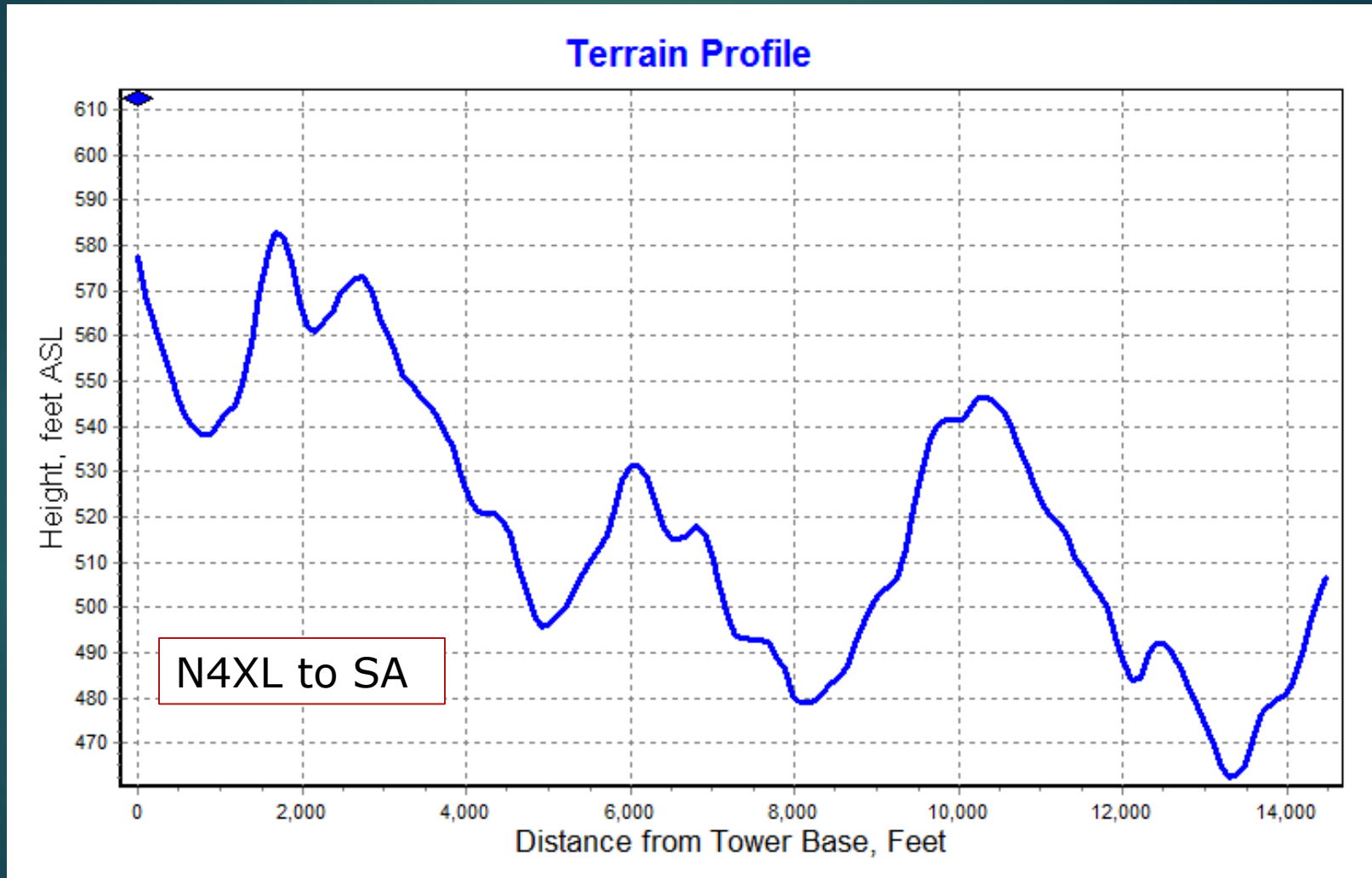

N4XL to EU at 50 ft

HFTA, Copyright ARRL 2003-2004, by N6BV, Ver. 1.03

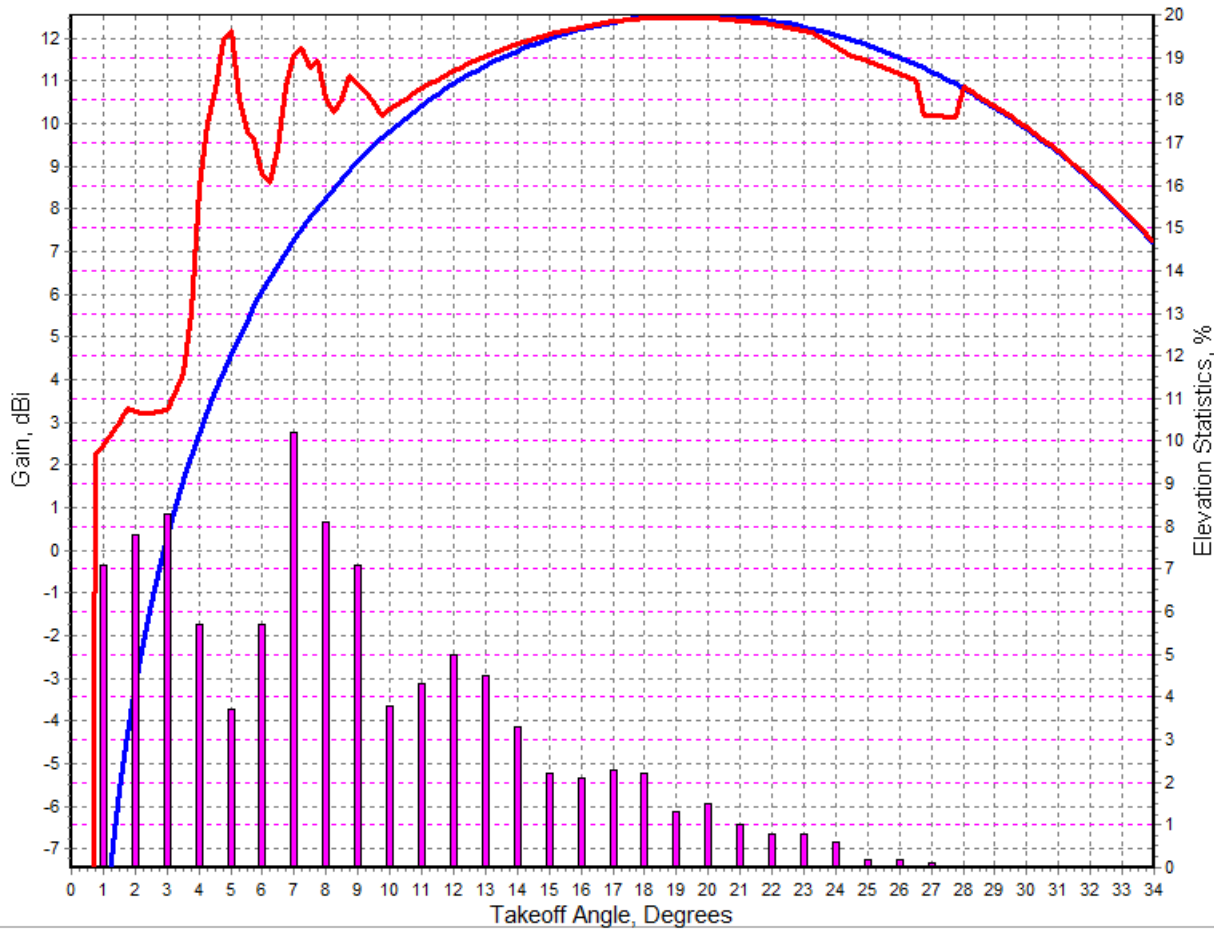

Freq. = 14.2 MHz
Max. Gain: 12.6 dBi

FLAT.PRO
50 ft
3-Ele.
Fig. of Merit: 8.7

NS4T-1-45.00.PRO
50 ft
3-Ele.
Fig. of Merit: 10.2

Elev. Statistic
W4-SC-EU.PRN

Print

Out File

Close

N4XL to SA at 50 ft

HFTA, Copyright ARRL 2003-2004, by N6BV, Ver. 1.03

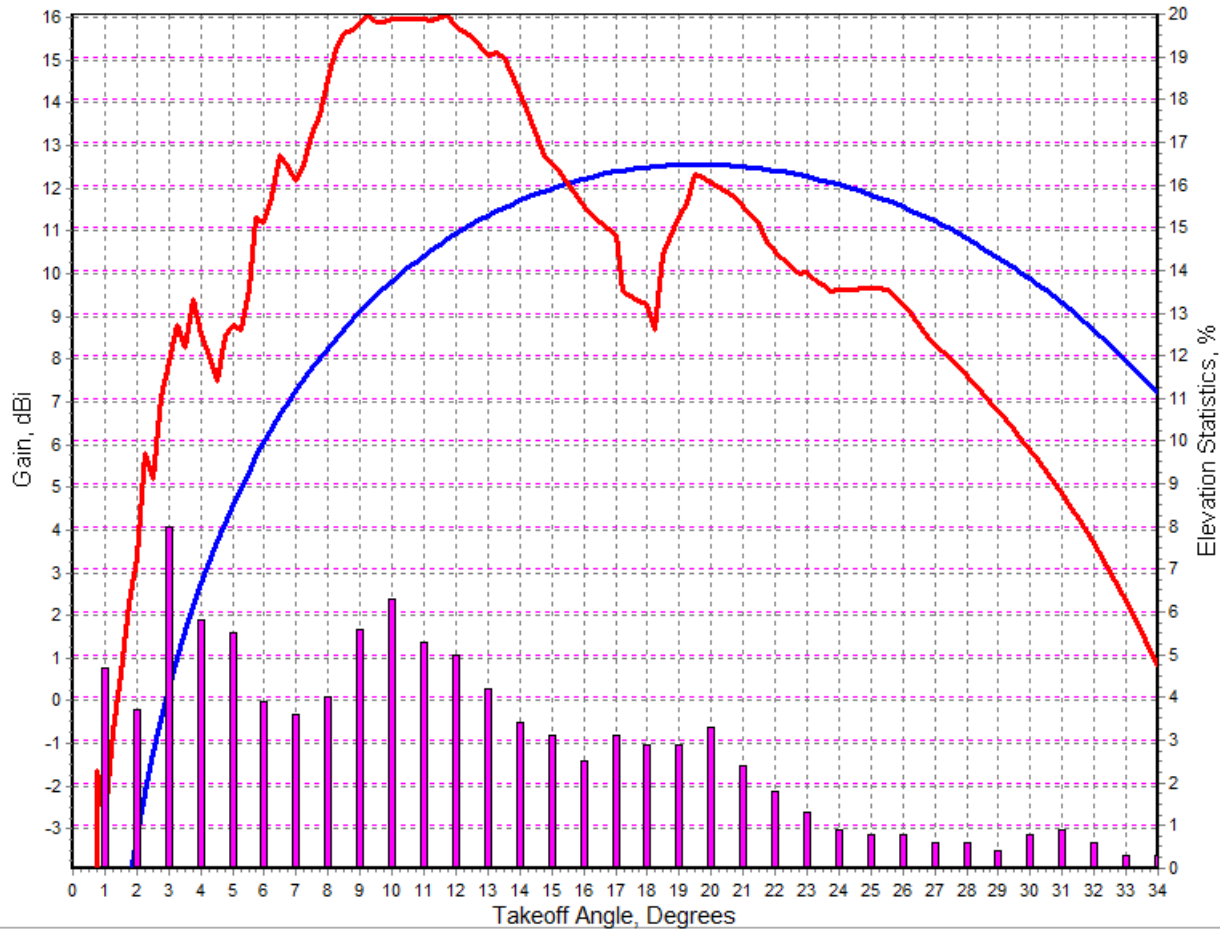

Freq. = 14.2 MHz
Max. Gain: 16.1 dBi

FLAT.PRO
50 ft
3-Ele.
Fig. of Merit: 9.6

NS4T-1-135.00.PRO
50 ft
3-Ele.
Fig. of Merit: 12.6

Elev. Statistic
W4-SC-SA.PRN

Print

Out File

Close

N4XL to EU at 50 or 70

HFTA, Copyright ARRL 2003-2004, by N6BV, Ver. 1.03

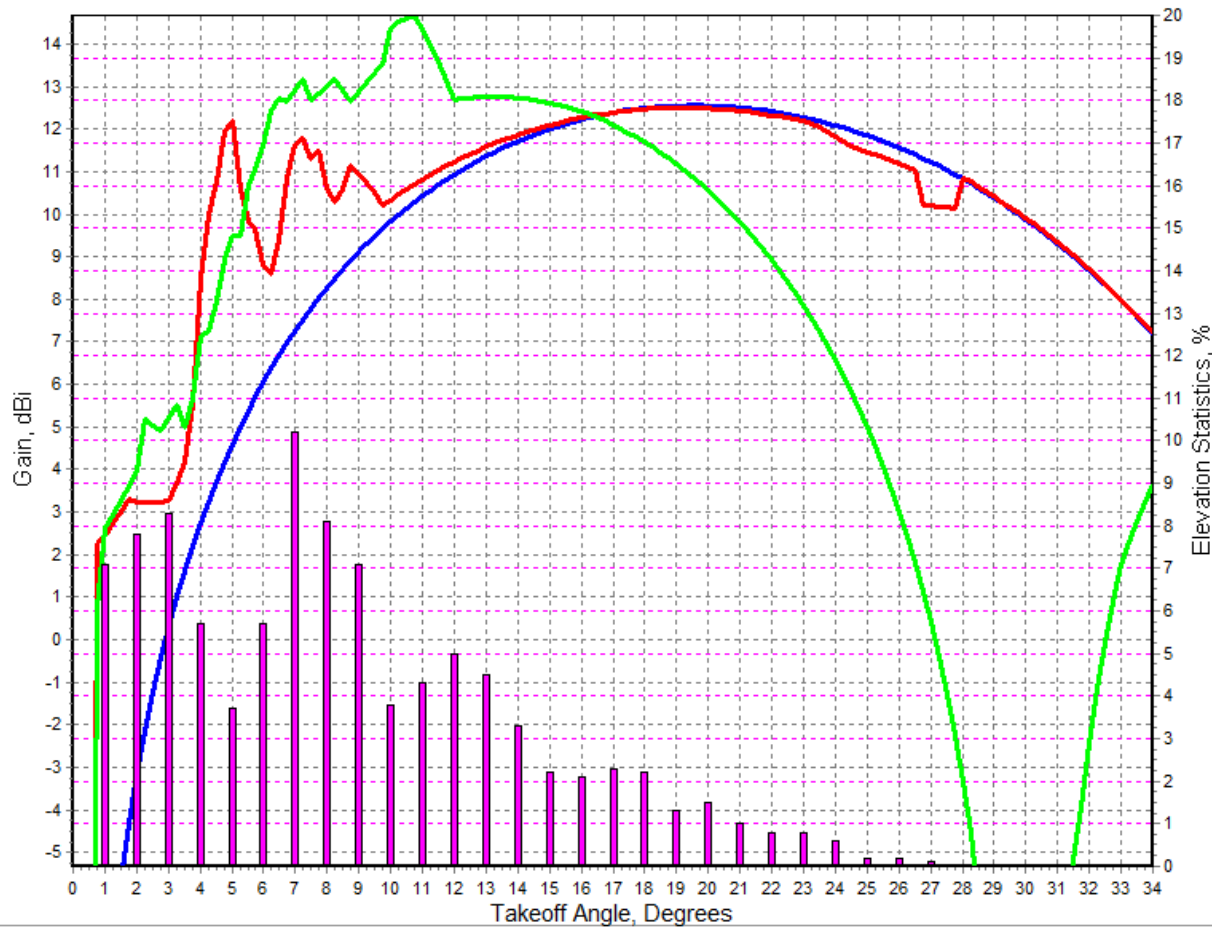

Freq. = 14.2 MHz

Max. Gain: 14.7 dBi

FLAT.PRO

50 ft

3-Ele.

Fig. of Merit: 8.7

NS4T-1-45.00.PRO

50 ft

3-Ele.

Fig. of Merit: 10.2

NS4T-1-45.00.PRO

70 ft

3-Ele.

Fig. of Merit: 11.4

Elev. Statistic

W4-SC-EU.PRN

Print

Out File

Close

N4XL to US at 50 or 70

HFTA, Copyright ARRL 2003-2004, by N6BV, Ver. 1.03

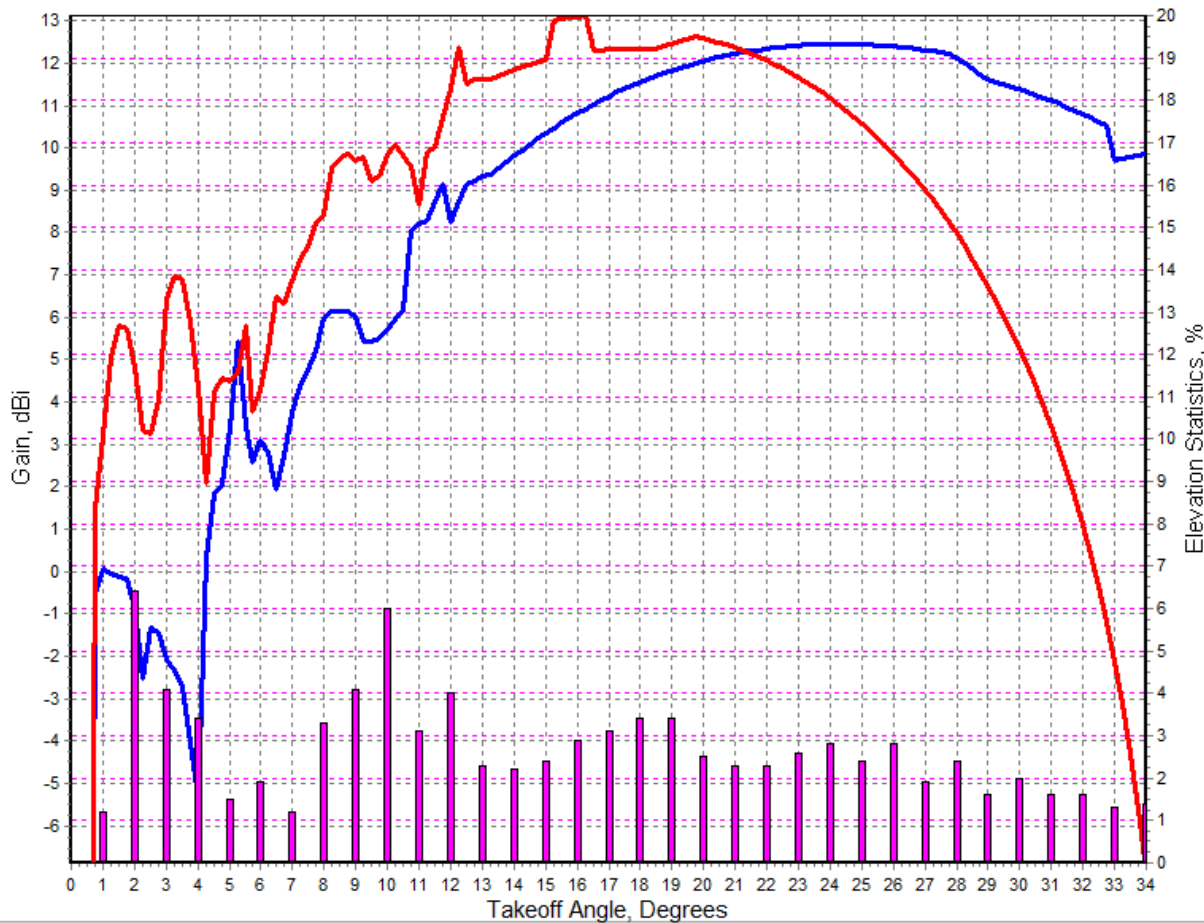

Freq. = 14.2 MHz

Max. Gain: 13.1 dBi

NS4T-1-290.00.PRO

50 ft

3-Ele.

Fig. of Merit: 9.3

NS4T-1-290.00.PRO

70 ft

3-Ele.

Fig. of Merit: 9.5

Elev. Statistic

W4-SC-US.PRN

Print

Out File

Close

N4XL to EU at 50 or 70 ft on 10 mtrs

HFTA, Copyright ARRL 2003-2004, by N6BV, Ver. 1.03

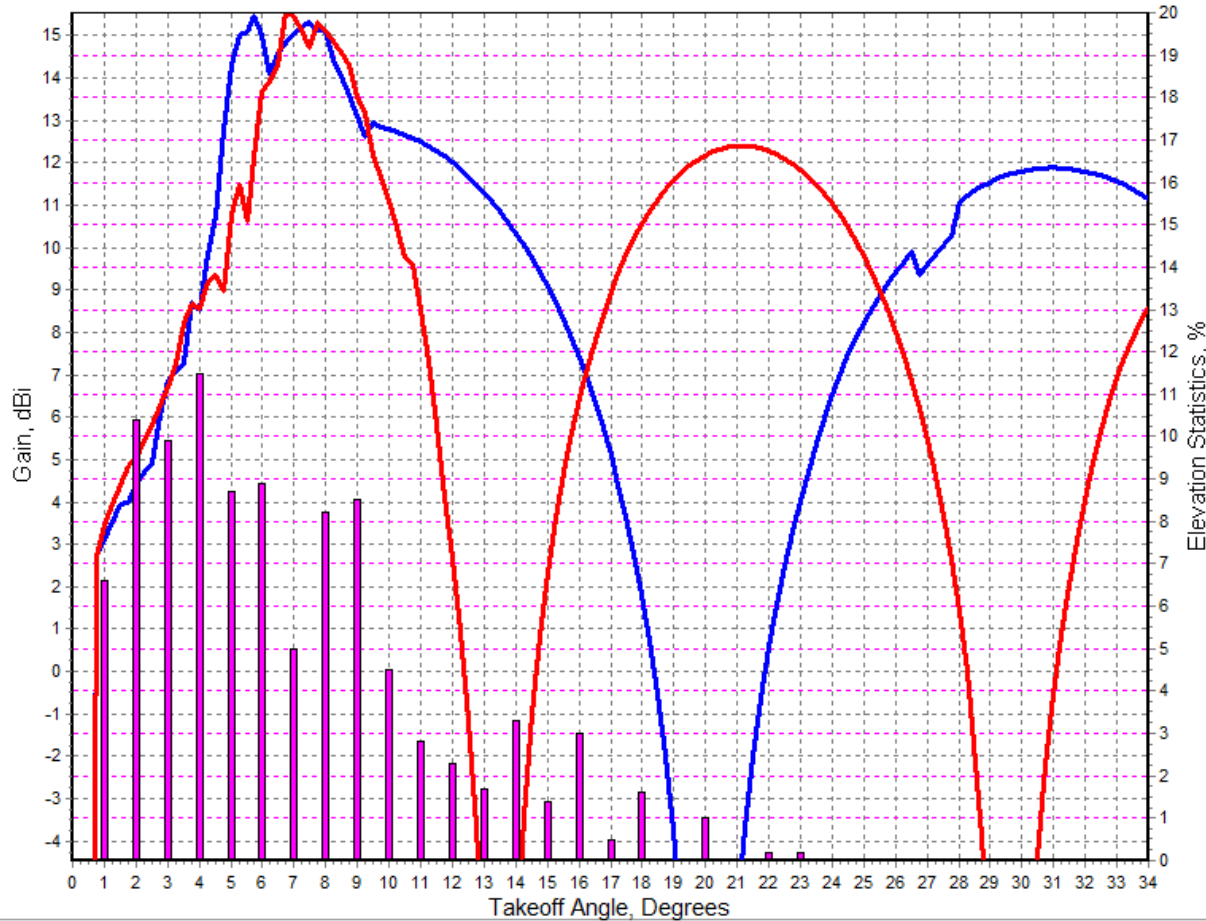

Freq. = 28.4 MHz

Max. Gain: 15.5 dBi

NS4T-1-45.00.PRO

50 ft

3-Ele.

Fig. of Merit: 11.9

NS4T-1-45.00.PRO

70 ft

3-Ele.

Fig. of Merit: 11

Elev. Statistic

W4-SC-EU.PRN

Print

Out File

Close

Using HFTA

- ▶ If you have a multi band antenna like a tribander or trapped dipole look at all frequencies and find a good compromise height
- ▶ Examine performance in several directions
- ▶ If you can put up more than one antenna, see what combination works best to cover the most angles

Sources for Terrain data

- ▶ K6TU website:
<https://www.k6tu.net/>
 - ▶ Free terrain downloads.
 - ▶ Pay for use features such as can integrate HFTA and VOACAP propagation predictions
- ▶ MicroDEM - complicated

N6BV comments

- ▶ Accuracy is ± 3 dB so don't obsess over small differences in plotted results
- ▶ Verify results by plotting three different heights one foot apart centered around the desired height. Compare those results and throw out any outlier.

N6BV comments

- ▶ HFTA analyzes horizontal polarization only. Best with directional arrays (Yagi's and Quads)
- ▶ Stacked antennas should be more than $\frac{1}{2}$ wavelength apart or false gain will be shown
- ▶ HFTA does not take into account manmade structures like water towers or buildings.

N6BV comments

- ▶ Elevation angles were computed for all the times over the 11-year solar cycle when each band is actually open. The degree to which the antennas chosen for a particular terrain cover all these angles, the more effective will be those antennas/terrain for all periods of the solar cycle

N6BV comments

- ▶ Figure of Merit (FOM) is only a “snapshot” of a complex situation. You can easily find situations where the elevation response of an antenna over complex terrain is better at low elevation angles than another antenna that has a higher FOM over the entire range of possible elevation angles. Low angles are especially important during periods of low solar activity, when the only possible modes of propagation are low-angle modes

N6BV comments

- ▶ ...if you are using Shuttle Radar Topographic Mission (SRTM) terrain data ... recognize that a radar will see the tops of trees in a dense forest, not necessarily seeing the underlying ground.
- ▶ On Dipoles: ... ray tracing is still only done in the forward direction, despite the fact that a dipole is bidirectional

Summary



- ▶ How well an antenna “plays” depends on take off angle to target area, antenna height, and local terrain
- ▶ Lower is sometimes better
- ▶ More than one antenna per band will help your overall signal presence
- ▶ Design your antenna farm to cover all angles

A Parting Thought



No antenna will do everything.
Each has pros and cons.

When someone asks you what
antenna they should put up you
should answer with a question.
“What is it you want to do most?”



Questions?



Thanks!